

Instructions. Students may bring two 8.5 x 11 pages of notes to this exam. On the exam, there are a set of short questions and 5 problems. All questions are worth 2 points and each problem is worth 16 points. All work and answers are to appear on this exam sheet. Attach additional sheets only if you run out of room on the examination itself.

If detailed information about a CMOS process is needed beyond what is specified in any problem on any question, consult the process information attached at the end of this exam. If any other process parameters are needed, specify clearly what process parameter is needed and specify a typical value for that parameter.

Questions

1. What is the fundamental reason that polysilicon is used rather than metal to form the gates of transistors in CMOS processes today?
2. Why are newer processes migrating to micron-based design rules rather than to lambda-based design rules?
3. Why is the minimum gate length in a state of the art CMOS process today?
4. How does Physical Vapor Deposition differ from Chemical Vapor Deposition?
5. What is the difference between sheet resistance and resistivity ?
6. If the n-doping level in a pn junction is larger than the p-doping level, will the resultant depletion region formed under reverse bias extend farther into the n-side or the p-side of the junction?
7. What is the difference between epitaxial silicon and polysilicon?
8. Why can SiO₂ not be thermally grown on top of metal?
9. What is a typical value for defect density in a high-volume semiconductor process?

10. Three methods for creating capacitors in a semiconductor process were discussed. What are they?

Problem 1 Assume you need to make a decision about whether it is economically viable to fabricate an integrated circuit in a CMOS process with 12inch wafers that cost \$2600 each. The customer indicated that the market will can support at most a good die cost of \$1.40. What is the maximum die area and that can be used for this design if you must keep the good die cost within the \$1.40 budget? Assume the only die loss is due to hard faults and the defect density is $1.5/\text{cm}^2$.

Problem 2 A static CMOS inverter is driving a load capacitance of $C_L=500\text{fF}$ as shown in the circuit diagram below. If an ideal 5V pulse is applied at the input, determine the rise and fall times of the inverter. Assume the transistor M_1 has width of 20μ and length of 1μ and transistor M_2 has a length of 2μ and a width of 5μ . The supply voltage is $V_{DD} = 5\text{V}$.

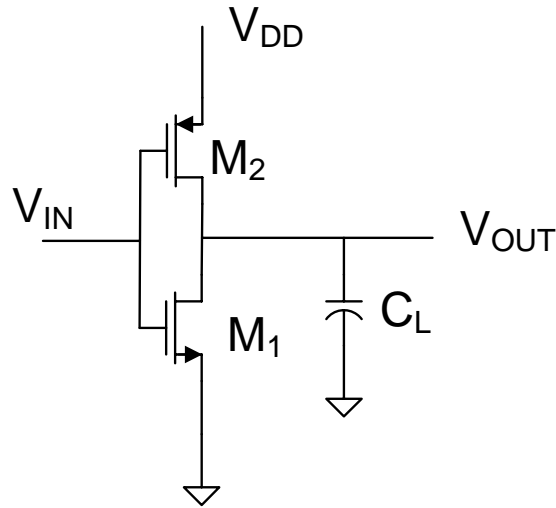

Problem 3 The routing to two circuit blocks (shown in shaded blue) designed in the AMI 0.5u process, is shown. Two bonding pads denoted with the letters A and B are also shown. This routing is not to scale but the key dimensions are given. If a dimension is not given, you may assume it is arbitrarily small or that the feature does not contribute to any interconnect problems. The red is Poly 1 and the blue is Metal 1. Both are 1u wide. The two loads are nominally 500 ohms and the goal of the designer was to distribute a bias of V_{DD} applied to pads A and B of 5V to the two blocks. What will the actual voltage be at the two blocks with this interconnect layout?

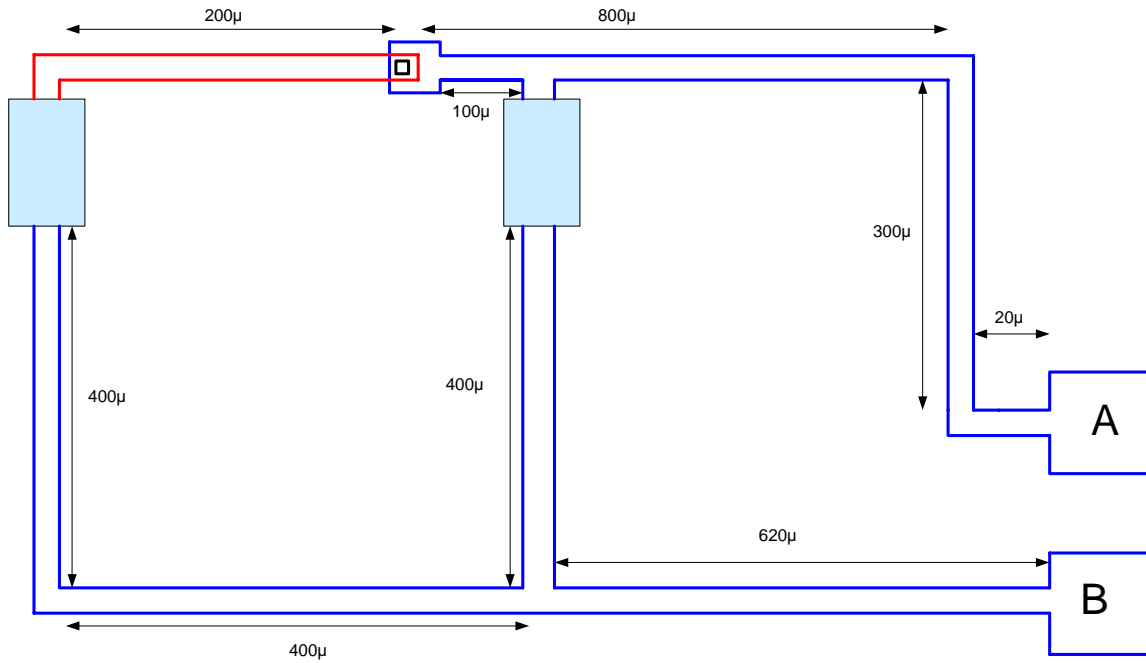

Problem 4 The layout of a circuit designed in the AMI 0.5u CMOS process is shown. Determine the current I_D that will flow in this circuit. (the color codes are Red- Poly 1, Green- n-active, Blue – Metal 1 and Black – contact. Use the process parameters listed on the last page of this exam to solve this problem.

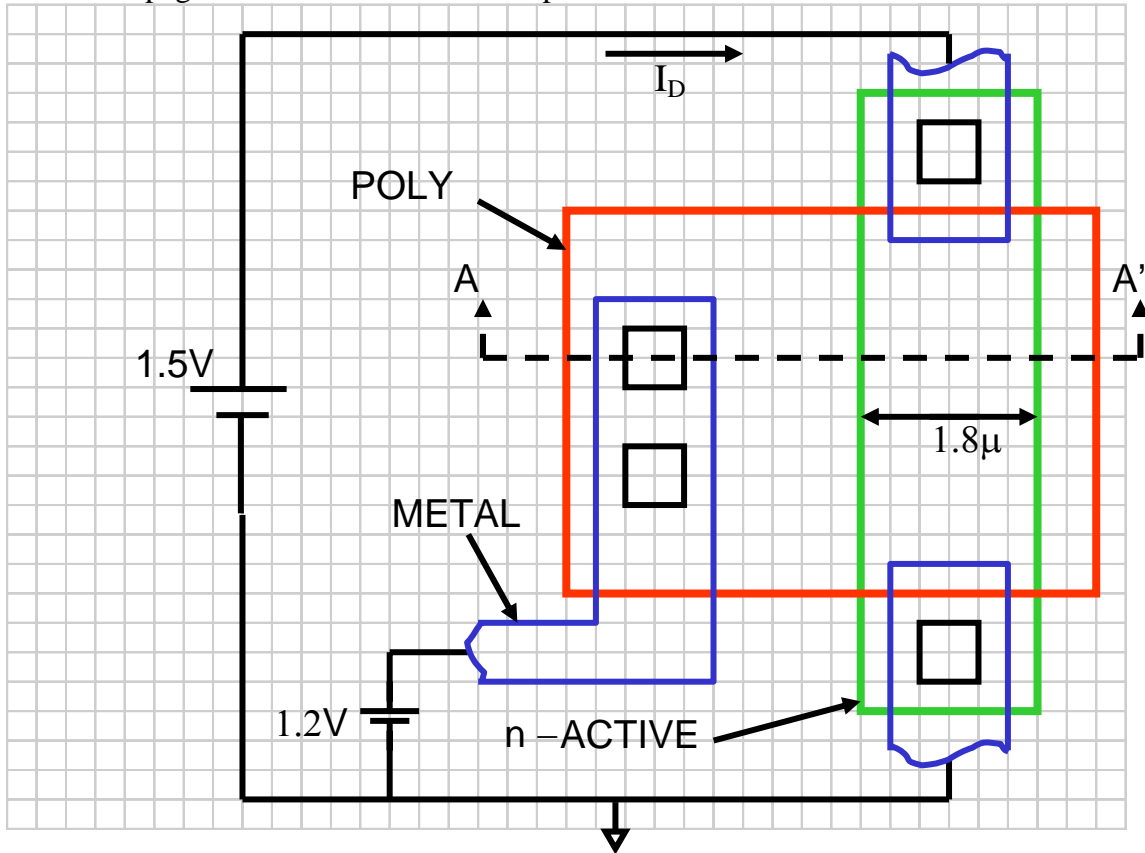

Problem 5 Sketch a cross-section view of the layout shown in Problem 4 along the AA' cross section line.

TRANSISTOR PARAMETERS	W/L	N-CHANNEL	P-CHANNEL	UNITS
MINIMUM	3.0/0.6			
Vth		0.78	-0.93	volts
SHORT	20.0/0.6			
Idss		439	-238	uA/um
Vth		0.69	-0.90	volts
Vpt		10.0	-10.0	volts
WIDE	20.0/0.6			
Ids0		< 2.5	< 2.5	pA/um
LARGE	50/50			
Vth		0.70	-0.95	volts
Vjbkd		11.4	-11.7	volts
Ijlk		<50.0	<50.0	pA
Gamma		0.50	0.58	V^0.5
K' (Uo*Cox/2)		56.9	-18.4	uA/V^2
Low-field Mobility		474.57	153.46	cm^2/V*s

COMMENTS: XL_AMI_C5F

FOX TRANSISTORS	GATE	N+ACTIVE	P+ACTIVE	UNITS
Vth	Poly	>15.0	<-15.0	volts

PROCESS PARAMETERS	N+ACTV	P+ACTV	POLY	PLY2_HR	POLY2	MTL1	MTL2	UNITS
Sheet Resistance	82.7	103.2	21.7	984	39.7	0.09	0.09	ohms/sq
Contact Resistance	56.2	118.4	14.6		24.0		0.78	ohms
Gate Oxide Thickness	144							angstrom

PROCESS PARAMETERS	MTL3	N\PLY	N_WELL	UNITS
Sheet Resistance	0.05	824	815	ohms/sq
Contact Resistance	0.78			ohms

COMMENTS: N\POLY is N-well under polysilicon.

CAPACITANCE PARAMETERS	N+ACTV	P+ACTV	POLY	POLY2	M1	M2	M3	N_WELL	UNITS
Area (substrate)	429	721	82		32	17	10	40	aF/um^2
Area (N+active)			2401		36	16	12		aF/um^2
Area (P+active)			2308						aF/um^2
Area (poly)				864	61	17	9		aF/um^2
Area (poly2)					53				aF/um^2
Area (metall)						34	13		aF/um^2
Area (metal2)								32	aF/um^2
Fringe (substrate)	311	256			74	58	39		aF/um
Fringe (poly)					53	40	28		aF/um
Fringe (metall)						55	32		aF/um
Fringe (metal2)								48	aF/um
Overlap (N+active)			206						aF/um
Overlap (P+active)			278						aF/um